

ID 3000

NON UTILIZZABILE SUI DISCHI STANDARD COREMO (Pag. 6)

NOT TO BE USED ON COREMO STANDARD DISCS (Page 6)

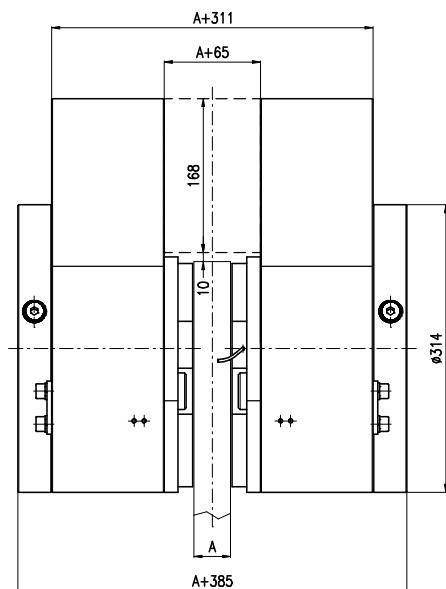
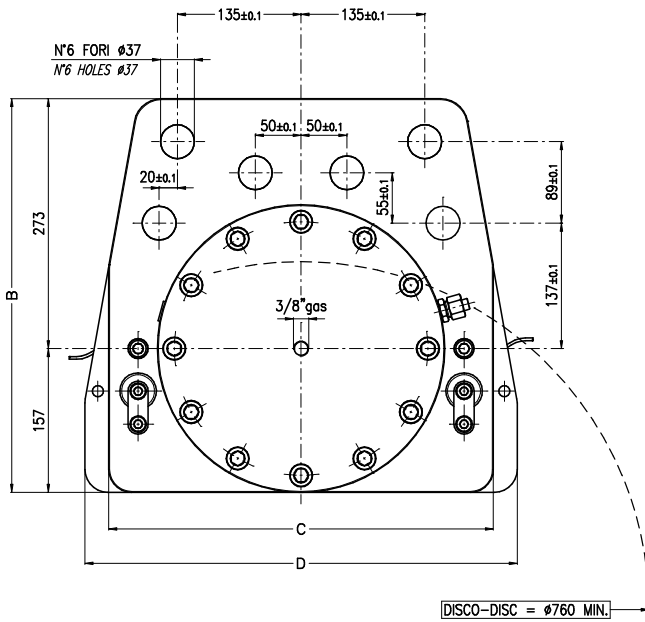

Lo spessore del supporto centrale deve essere uguale allo spessore del disco + 65 mm
The thickness of center mounting bracket must be same as disc thickness + 65 mm

DIMENSIONI DIMENSIONS

TIPO TYPE	Codice prodotto Product Number	A	B	C	D	Volume olio Oil Volume dm ³	Peso Weight kg
ID 3000	A4016	Spess. disco Disc thick.	430	420	472	2.0	369

Attenzione: La coppia iniziale può essere dal 30% al 50% in meno rispetto al valore nominale, fino all'assestamento del ferodo sul disco.
Warning: The initial torque on new units can be 30% to 50% less than the catalogue value until the friction facing and friction disc are lapped or worn in.

DATI TECNICI

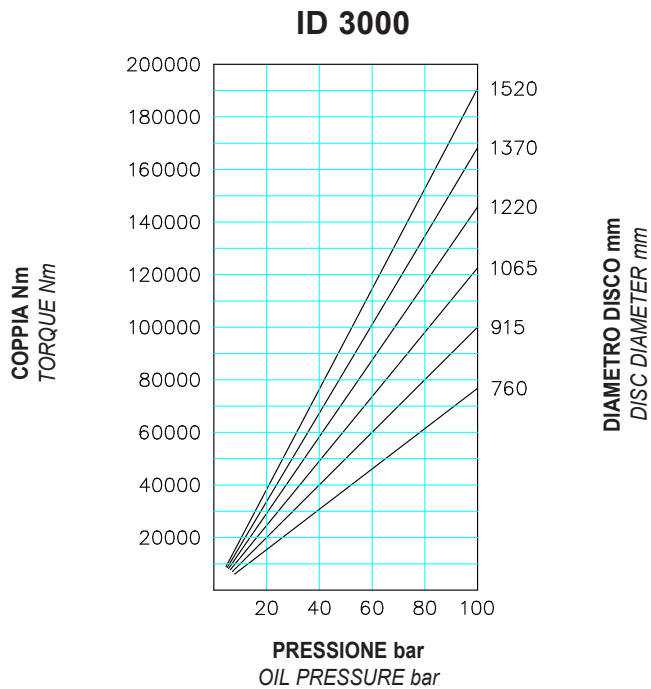

Forza tangenziale F:

ID 3000 300000 N a 100 bar

Coppia dinamica
= $F \cdot (\text{raggio del disco in m} - 0.124) = \text{Nm}$

Pressione max: 100 bar

Usura max totale: 20 mm

Spessore del ferodo nuovo: 16 mm

Dissipazione del calore in continuo
Qc: 80 kW

Tipo di olio:

olio a base minerale SAE/ISO 46

Volume olio per uno spostamento
di 2 mm per ciascun ferodo: 0.2 dm³

DIAGRAMMA CHART

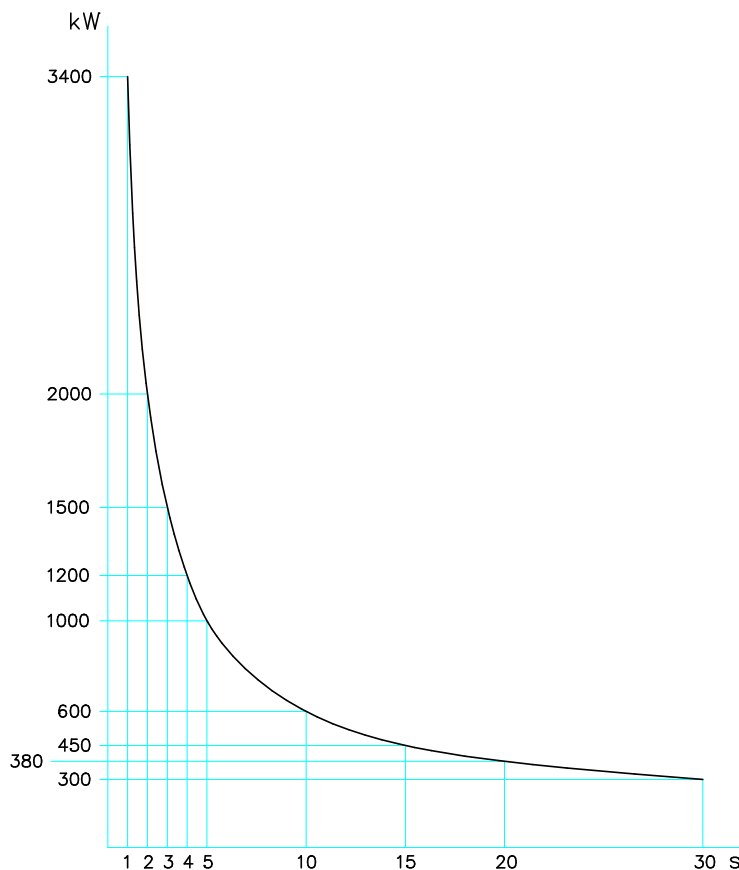

Dissipazione
di calore
per frenatura
di emergenza

Thermal capacity
for emergency stop

TECHNICAL DATA

Braking force F:

ID 3000 300000 N at 100 bar

Dynamic torque

= $F \cdot (\text{disc radius in m} - 0.124) = \text{Nm}$

Max pressure: 100 bar

Max total wear: 20 mm

Thickness of new lining: 16 mm

Continuous thermal capacity

Qc: 80 kW

Hydraulic fluid:

Mineral oil based SAE/ISO 46

Total oil displacement for 2 mm
movement of each pad: 0.2 dm³