

F3-ID

Disponibile anche per disco spessore 25.4 - 30 - 40 mm.

Available also for disc thickness 25.4 - 30 - 40 mm.

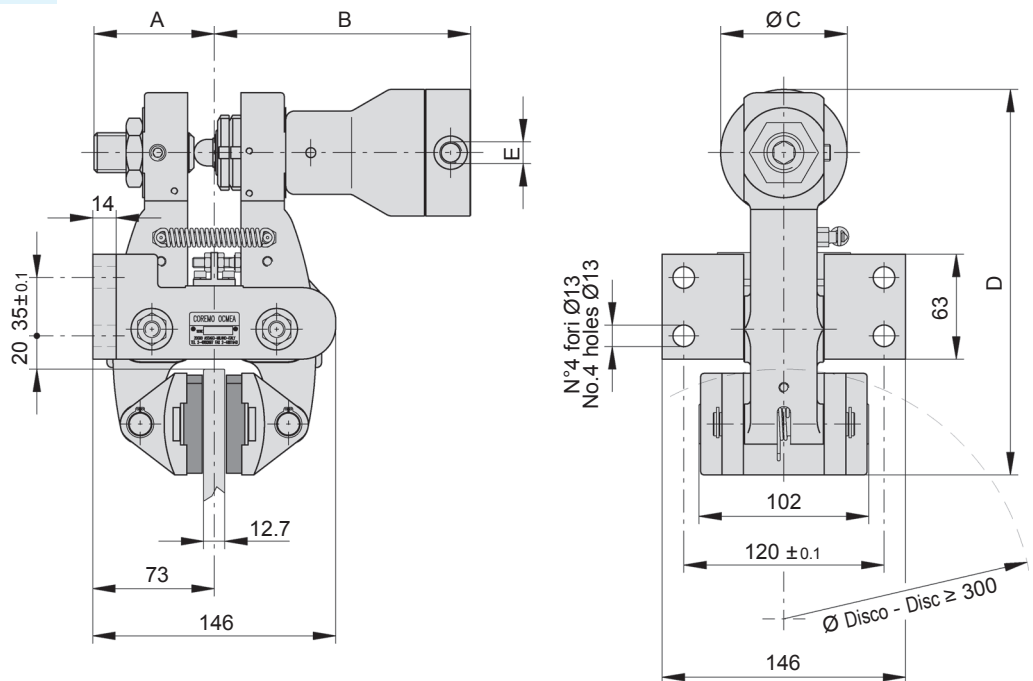

DIMENSIONI DIMENSIONS

TIPO SIZE	Cod. Prodotto Product Number	A	B	ØC	D	E	Volume olio Oil Volume dm ³	Peso Weight kg
F3-ID	A2814	72	154	76	231.5	1/8" gas	0.025	11

Attenzione: La coppia iniziale può essere dal 30% al 50% in meno rispetto al valore nominale, fino all'assestamento del ferodo sul disco.
Warning: The initial torque on new units can be 30% to 50% less than the catalogue value until the friction facing and friction disc are lapped or worn in.

DATI TECNICI

Forza tangenziale F:

F3-ID 14868 N a 100 bar

Coppia dinamica
= $F \cdot (\text{raggio del disco in m} - 0.033) = \text{Nm}$

Pressione max: 100 bar

Usura max totale: 12 mm

Spessore del ferodo nuovo: 11 mm

Dissipazione del calore in continuo
Qc: 3.4 kW

Tipo di olio:

olio a base minerale SAE/ISO 46

Volume olio per uno spostamento
di 2 mm per ciascun ferodo: 0.008 dm³



DIAGRAMMA CHART



Dissipazione
di calore
per frenatura
di emergenza

Thermal capacity
for emergency stop

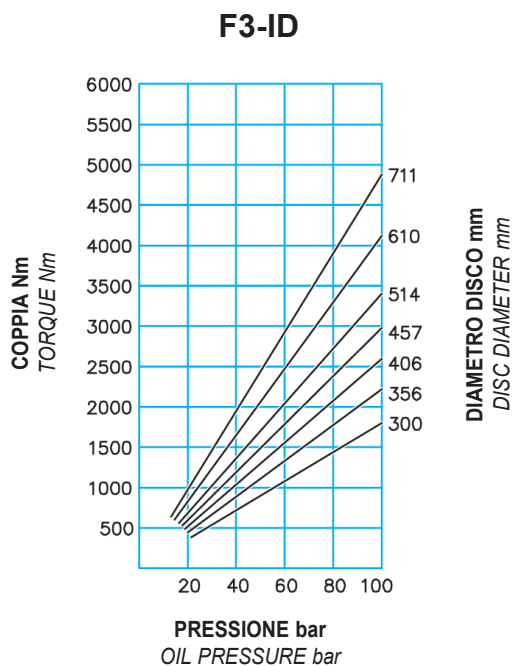
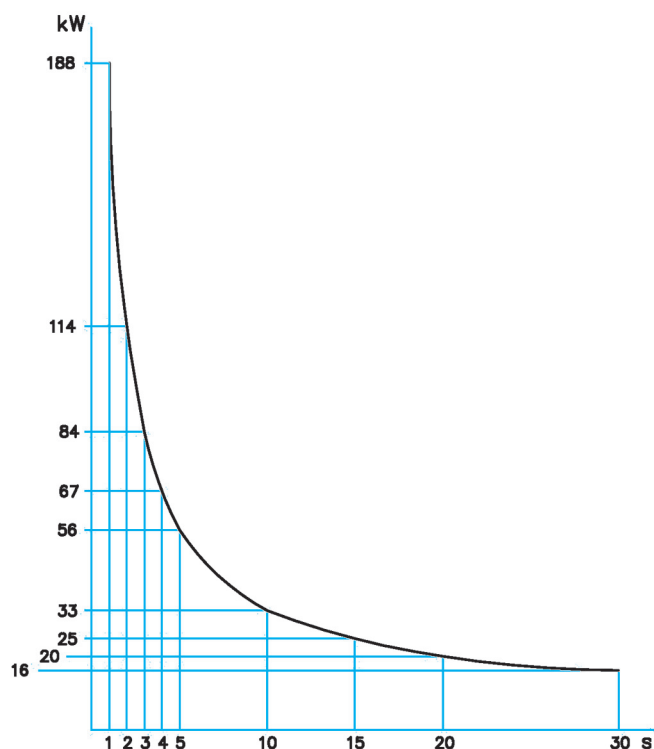
TECHNICAL DATA

Braking force F:

F3-ID 14868 N at 100 bar

Dynamic torque
= $F \cdot (\text{disc radius in m} - 0.033) = \text{Nm}$

Max pressure: 100 bar

Max total wear: 12 mm

Thickness of new linings: 11 mm

Continuous thermal capacity
Qc: 3.4 kW

Hydraulic fluid:

Mineral oil based SAE/ISO 46

Total oil displacement for 2 mm
movement of each pad: 0.008 dm³